

TENTATIVE SUBDIVISION MAP FOR:

FOUR 40 WEST

CITY OF WEST SACRAMENTO

CALIFORNIA

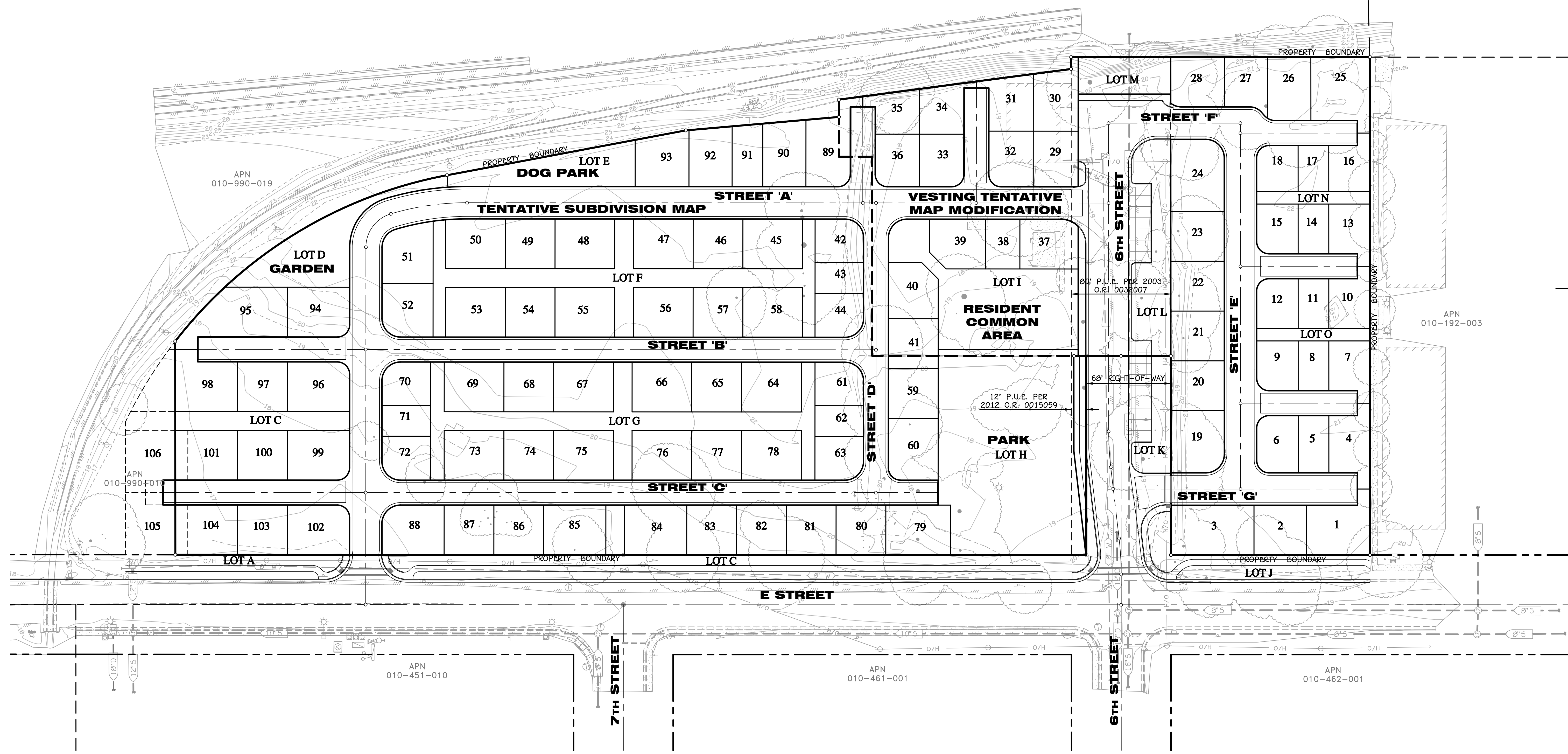
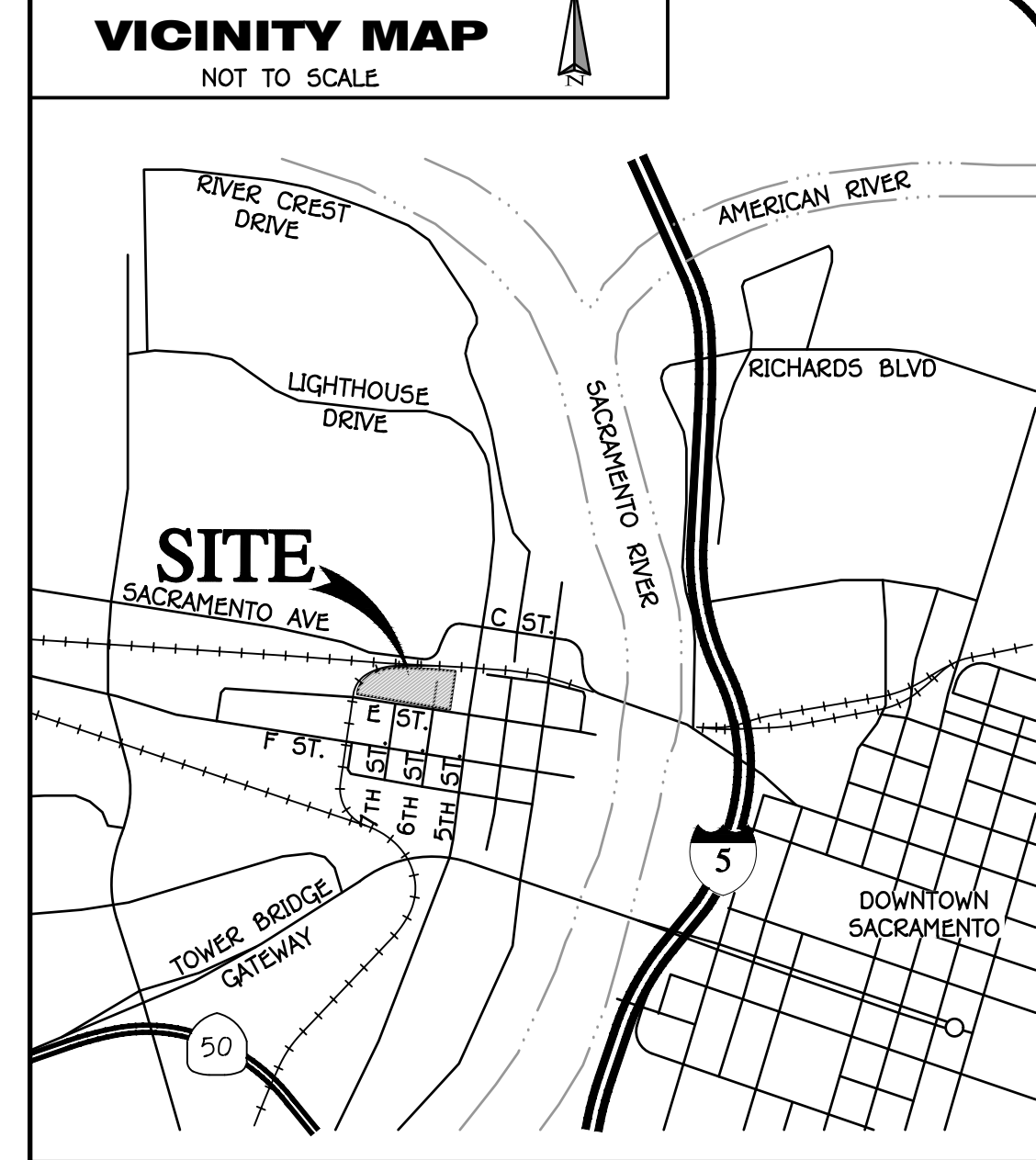
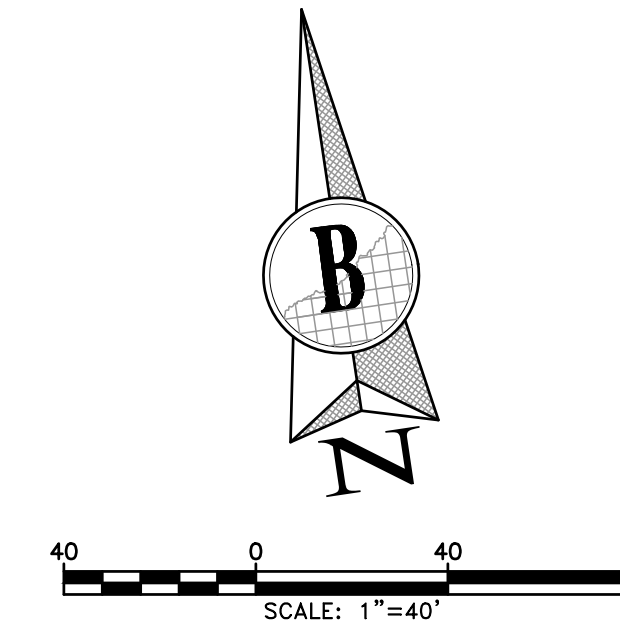

GENERAL NOTES

ASSESSORS PARCEL NUMBERS	010-191-004, 010-191-005, 010-191-006, 010-191-011, 010-191-012, 010-191-013, 010-191-017, 010-191-018 & 010-192-003
EXISTING ZONING	R-3
EXISTING USE	RESIDENTIAL
PROPOSED ZONING	R-3
PROPOSED USE	RESIDENTIAL
FEMA FLOOD ZONE	X
OWNER/DEVELOPER	BLACKPINE 440 WEST, LLC 8000 CAL CENTER DRIVE, SUITE 350 SACRAMENTO, CA 95826 ATTN: MIKE PARIS (916) 497-0900
ENGINEER	BURRELL CONSULTING GROUP 1001 ENTERPRISE WAY, ST. 100 ROSEVILLE, CA 95678 ATTN: JERRY APLASS (916) 783-8898
NUMBER OF EXISTING LOTS	9
NUMBER OF PROPOSED LOTS	106 SINGLE FAMILY RESIDENTIAL + 11 LOTS
SIZE OF LOTS	SEE MAP
GROSS ACREAGE	8.15+ AC.
NET ACREAGE	7.40+ AC.

UTILITY DISTRICTS

SANITARY SEWER	CITY OF WEST SACRAMENTO
WATER	CITY OF WEST SACRAMENTO
STORM DRAINAGE	CITY OF WEST SACRAMENTO
ELECTRICITY	PACIFIC GAS & ELECTRIC
TELEPHONE	AT&T
NATURAL GAS	PACIFIC GAS & ELECTRIC
PUBLIC IMPROVEMENTS	CITY OF WEST SACRAMENTO ENGINEERING DIVISION

PUBLIC SERVICES

SCHOOL DISTRICT	WASHINGTON UNIFIED SCHOOL DISTRICT
PARK DISTRICT	CITY OF WEST SACRAMENTO PARKS & REC.
FIRE DISTRICT	WEST SACRAMENTO FIRE DEPARTMENT

NOTES:

ANY EXISTING SEPTIC TANKS AND/OR WELLS WILL BE ABANDONED PURSUANT TO THE ENVIRONMENTAL MANAGEMENT REQUIREMENTS.

ALL KNOWN EASEMENTS HAVE BEEN PLOTTED AND ACCOUNTED FOR AND SIGNED.

THIS TENTATIVE MAP IS A GRAPHIC REPRESENTATION OF THE SUBJECT SITE. THE LOCATION OF THE PROPERTY LINES HAVE NOT BEEN DETERMINED AT THIS TIME. PROPERTY LINE DIMENSIONS SHOWN HEREON ARE APPROXIMATE ONLY AND MAY BE SUBJECT TO CHANGE ONCE A FINAL BOUNDARY SURVEY IS COMPLETED.

LEGEND

DESCRIPTIONS	(P) PROPOSED	(E) EXISTING
CENTERLINE	---	---
RIGHT OF WAY LINE	---	---
BOUNDARY LINE	---	---
ELECTRICAL LINE	---	---
GAS LINE	---	---
TELEPHONE LINE	---	---
SIDEWALK WITH CURB AND GUTTER	---	---

LEGAL DESCRIPTION

THE LAND DESCRIBED HEREIN IS SITUATED IN THE STATE OF CALIFORNIA, COUNTY OF YOLO, CITY OF WEST SACRAMENTO, DESCRIBED AS FOLLOWS:

PARCEL ONE:

LOTS 19 AND 20, BLOCK 28, TOWN OF WASHINGTON, FILED JUNE 26, 1869 IN BOOK 1 OF DEEDS, AT PAGES 264 AND 265, YOLO COUNTY RECORDS, TOGETHER WITH THAT PORTION OF WESTERLY ONE-HALF OF SIXTH STREET VACATED BY RESOLUTION NO. 00-38, RECORDED JUNE 3, 2003, INSTRUMENT NO. 2003-0032007, YOLO COUNTY RECORDS.

EXCEPTING THEREFROM THE FOLLOWING:

BEGINNING AT THE NORTHEAST CORNER OF SAID LOT 19; THENCE ALONG THE EASTERLY LINE OF SAID LOT 19, SOUTH 8°33'30" WEST, 9.50 FEET; THENCE LEAVING SAID EASTERLY LINE, NORTH 80°56'19" WEST, 53.66 FEET TO A POINT ON THE WESTERLY LINE OF SAID LOT 20; THENCE ALONG SAID WESTERLY LINE NORTH 8°33'30" EAST, 16.50 FEET TO THE NORTHWESTERLY CORNER OF SAID LOT 20; THENCE ALONG THE NORTHERLY LINE OF SAID LOTS 20 AND 19, SOUTH 81°26'30" EAST, 53.20 FEET TO THE POINT OF BEGINNING.

ALSO EXCEPTING THEREFROM, ANY PORTION OF THE HEREIN DESCRIBED LAND THAT MAY LIE WITHIN THE LANDS OF THE SOUTHERN PACIFIC RAILROAD OR ITS SUCCESSORS, THAT ARE WITHIN THAT PORTION OF SIXTH STREET AS VACATED BY RESOLUTION NO. 00-38, RECORDED JUNE 3, 2003, AS INSTRUMENT NO. 2003-0032007, YOLO COUNTY RECORDS.

APN: 010-191-011-000

PARCEL TWO:

A PORTION OF LOT 21, BLOCK 28, TOWN OF WASHINGTON, FILED JUNE 26, 1869 IN BOOK 1 OF DEEDS, PAGES 264 AND 265, YOLO COUNTY RECORDS, MORE PARTICULARLY DESCRIBED AS FOLLOWS:

BEGINNING AT A POINT IN THE EASTERLY LINE OF SAID LOT 21 THAT IS DISTANT SOUTH 8°33'30" WEST, THEREON 16.50 FEET FROM THE NORTHEASTERLY CORNER OF SAID LOT 21; THENCE ALONG SAID EASTERLY LINE, SOUTH 8°33'30" WEST, 63.50 FEET TO A POINT ON THE SOUTHERLY LINE OF SAID LOT 21; THENCE ALONG SAID SOUTHERLY LINE NORTH 81°26'30" WEST, 26.60 FEET TO A POINT ON THE WESTERLY LINE OF SAID LOT 21; THENCE ALONG SAID WESTERLY LINE NORTH 8°33'30" EAST, 60.00 FEET; THENCE LEAVING SAID WESTERLY LINE, SOUTH 80°56'19" EAST, 56.83 FEET TO THE POINT OF BEGINNING.

EXCEPTING THEREFROM ALL OF THE MINERALS AND MINERAL ORES OF EVERY KIND AND CHARACTER NOW KNOWN TO EXIST OR HEREAFTER DISCOVERED UPON, WITHIN OR UNDERLYING LIMITING THE GENERALITY OF THE FOREGOING, ALL PETROLEUM, OIL, NATURAL GAS OR OTHER HYDROCARBON SUBSTANCES AND PRODUCTS DERIVED THEREFROM, TOGETHER WITH THE EXCLUSIVE AND PERPETUAL RIGHT OF SAID GRANTOR, ITS SUCCESSORS AND ASSIGNS, OR INGRESS AND EGRESS BENEATH THE SURFACE OF SAID PROPERTY TO EXPLORE FOR, EXTRACT, MINE AND REMOVE THE SAME, AND TO MAKE SUCH USE OF THE SAID PROPERTY BENEATH THE SURFACE AS IS NECESSARY OR USEFUL IN CONNECTION THEREWITH, WHICH USE MAY INCLUDE LATERAL OR SLANT DRILLING, BORING, DRILLING, BORING, DIGGING OR SINKING OF WELLS, SHAFTS OR TUNNELS; PROVIDED, HOWEVER, THAT SAID GRANTOR, ITS SUCCESSORS AND ASSIGNS, SHALL NOT USE THE SURFACE OF SAID PROPERTY IN THE EXERCISE OF ANY OF SAID RIGHTS, AND SHALL NOT DISTURB THE SURFACE OF SAID PROPERTY, OR ANY IMPROVEMENTS THEREON, AS RESERVED BY SOUTHERN PACIFIC COMPANY IN DEED RECORDED APRIL 16, 1958 IN BOOK 539 OF OFFICIAL RECORDS, AT PAGE 433, YOLO COUNTY RECORDS.

CLTA PRELIMINARY REPORT (11-17-06) PAGE 3 OF 22

APN: 010-191-017-000 (PORTION)

PARCEL THREE:

LOTS 22, 23, 24 AND 25, BLOCK 28, TOWN OF WASHINGTON, FILED JUNE 26, 1869 IN BOOK 1 OF DEEDS, PAGES 264 AND 265, YOLO COUNTY RECORDS.

EXCEPTING THEREFROM THE FOLLOWING:

BEGINNING AT THE NORTHEASTERLY CORNER OF SAID LOT 22; THENCE ALONG THE EASTERLY LINE OF SAID LOT 22, SOUTH 8°33'30" WEST, 20.00 FEET; THENCE LEAVING SAID EASTERLY LINE, NORTH 80°56'19" WEST, 108.12 FEET TO A POINT ON THE WESTERLY LINE OF SAID LOT 25; THENCE ALONG SAID WESTERLY LINE NORTH 8°33'30" EAST, 34.10 FEET TO THE NORTHWESTERLY CORNER OF SAID LOT 25; THENCE ALONG THE NORTHERLY LINE OF SAID LOTS 25, 24, 23 AND 22, SOUTH 81°26'30" EAST, 107.20 FEET TO THE POINT OF BEGINNING.

APN: 010-191-017-000 (PORTION)

PARCEL FOUR:

LOTS 17 AND 18, BLOCK 28, TOWN OF WASHINGTON, FILED JUNE 26, 1869 IN BOOK 1 OF DEEDS, PAGES 264 AND 265, YOLO COUNTY RECORDS, TOGETHER WITH THAT PORTION OF THE WESTERLY ONE-HALF OF SIXTH STREET VACATED BY RESOLUTION NO. 00-38, RECORDED JUNE 3, 2003, AS INSTRUMENT NO. 2003-0032007, YOLO COUNTY RECORDS.

APN: 010-191-012-000, 010-191-013-000

PARCEL FIVE:

LOTS 7, 8, 9, 10, 11, 12, 13, 14, 15, 25, 26, 27, 28, 29 AND 30, BLOCK 23, TOWN OF WASHINGTON, FILED JUNE 26, 1869 IN BOOK 1 OF DEEDS, PAGE 264, YOLO COUNTY RECORDS.

TOGETHER WITH THAT PORTION OF SIXTH STREET VACATED IN THE RESOLUTION RECORDED JUNE 3, 2003 AS INSTRUMENT NO. 2003-0032007, OFFICIAL RECORDS.

APN: 010-192-003-000

PARCEL SIX:

ALL THAT PORTION OF BLOCKS 28 AND 33, AS SAID BLOCKS ARE SHOWN ON THE PLAT OF THE TOWN OF WASHINGTON, IN THE CITY OF WEST SACRAMENTO, COUNTY OF YOLO, STATE OF CALIFORNIA, FILED JUNE 26, 1869 IN BOOK 1 OF DEEDS, PAGES 264 AND 265, YOLO COUNTY RECORDS (TOGETHER WITH THAT PORTION OF ABANDONED SEVENTH STREET WHICH WOULD ATTACH BY DUE PROCESS OF LAW), DESCRIBED AS FOLLOWS:

BEGINNING AT THE MOST SOUTHERLY CORNER OF LOT 3 OF BLOCK 28; THENCE FROM SAID POINT OF BEGINNING, ALONG THE SOUTHWESTERLY BOUNDARIES OF LOTS 3 THROUGH 12, BLOCK 28, INCLUSIVE, SAID ABANDONED PORTION OF SEVENTH STREET AND LOTS 1 THROUGH 12, BLOCK 33, INCLUSIVE, RESPECTIVELY, SAID BOUNDARIES ALSO BEING THE NORTHEASTERLY RIGHT-OF-WAY LINE OF E STREET, NORTH 81°20'00" WEST 666.67 FEET TO THE MOST WESTERLY CORNER OF BLOCK 33; THENCE ALONG THE NORTHWESTERLY BOUNDARIES OF LOTS 12, 13 AND 14, BLOCK 33, RESPECTIVELY, NORTH 08°40'00" EAST 171.44 FEET; THENCE LEAVING SAID NORTHWESTERLY BOUNDARIES, CURVING TO THE RIGHT ON AN ARC OF 360.60 FEET RADIUS, SAID ARC BEING SUBTENDED BY A CHORD BEARING NORTH 67°13'12" EAST 256.08 FEET; THENCE NORTH 80°01'05" EAST 195.19 FEET; THENCE SOUTH 86°22'19" EAST 123.91 FEET TO A POINT ON THE SOUTHEASTERLY BOUNDARY OF LOT 26, BLOCK 28; THENCE ALONG SAID BOUNDARY, SOUTH 08°40'00" WEST 31.96 FEET TO A POINT ON THE NORTHEASTERLY BOUNDARY OF CLTA PRELIMINARY REPORT (11-17-06)

APN: 010-191-011-000, 010-191-017-000, 010-191-012-000, 010-191-013-000, 010-192-003-000, 010-191-017-000 (PORTION)

TENTATIVE SUBDIVISION MAP FOR:

FOUR 40 WEST

E STREET
CITY OF WEST SACRAMENTO, CALIFORNIA
JANUARY 14, 2021
SHEET 1 OF 3

1001 Enterprise Way, Suite 100 Roseville, CA 95678 (916) 783-8898

TENTATIVE SUBDIVISION MAP FOR:

FOUR 40 WEST

CITY OF WEST SACRAMENTO

CALIFORNIA

VICINITY MAP
NOT TO SCALE

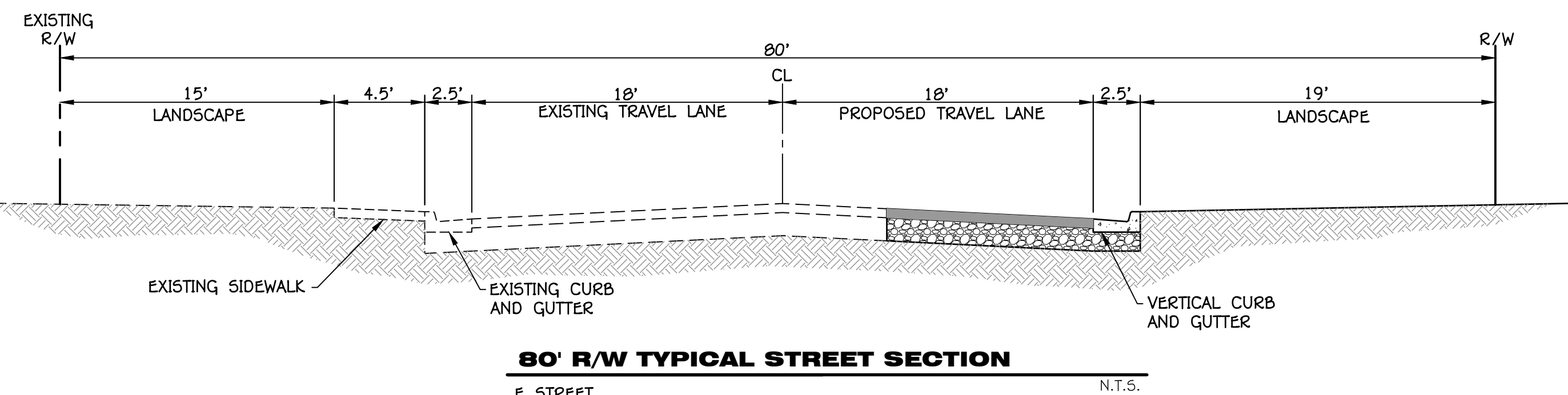
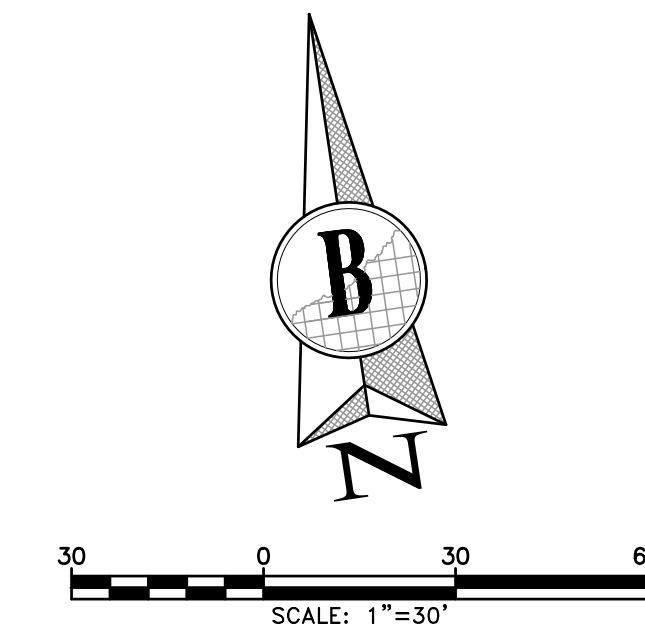
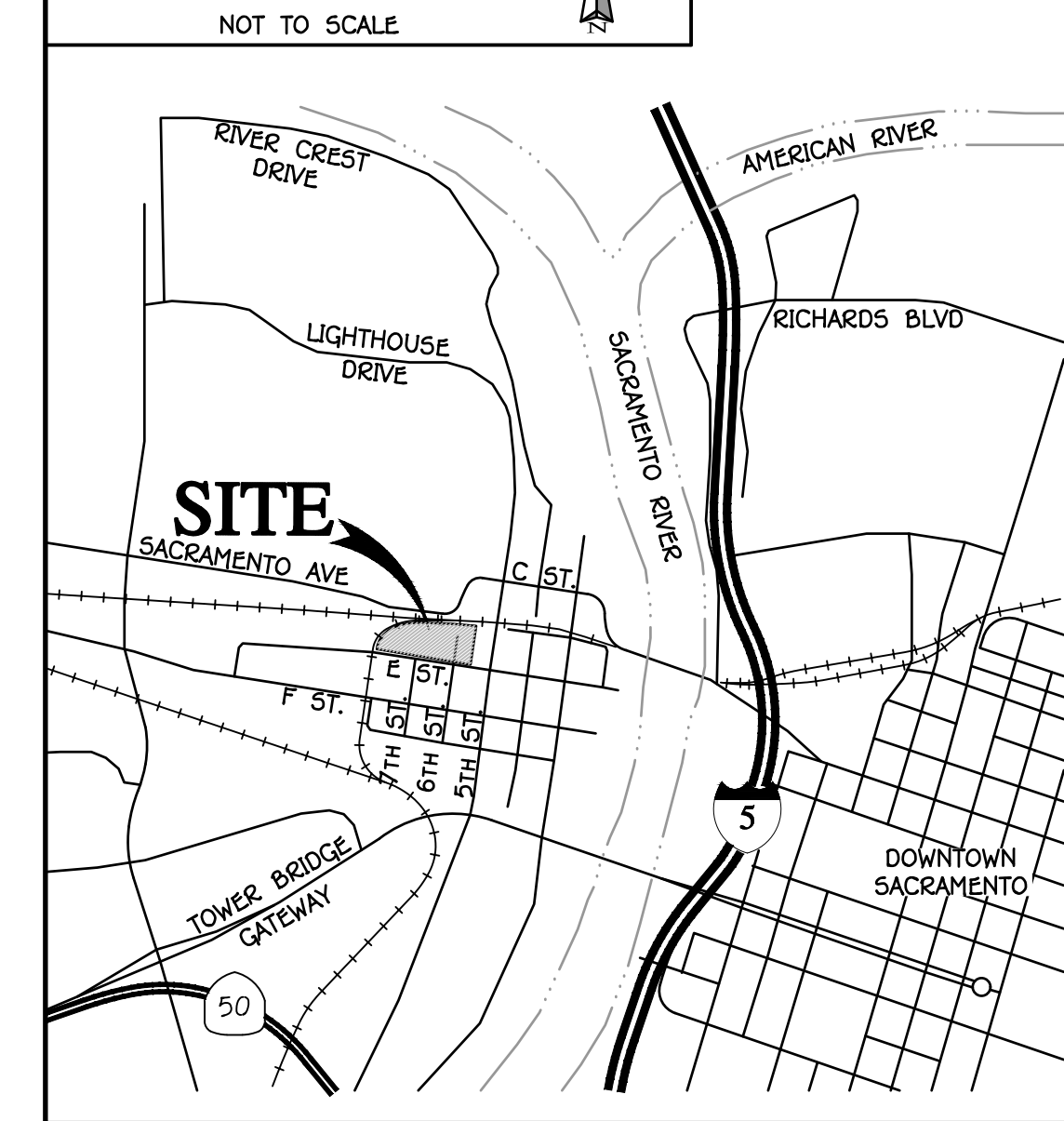

80' R/W TYPICAL STREET SECTION

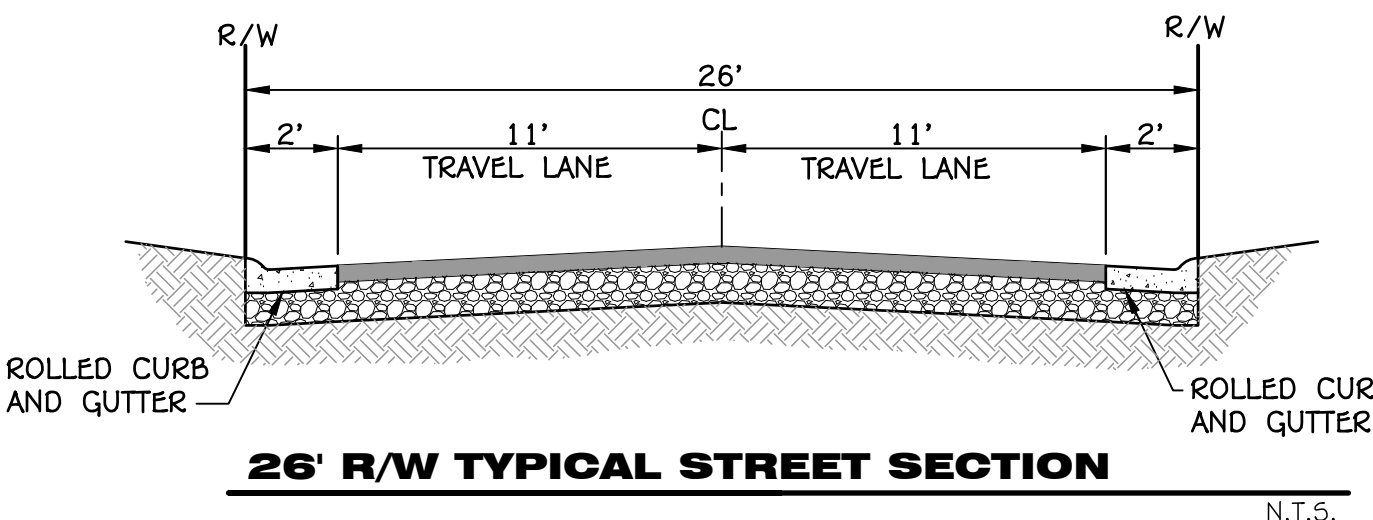

26' R/W TYPICAL STREET SECTION

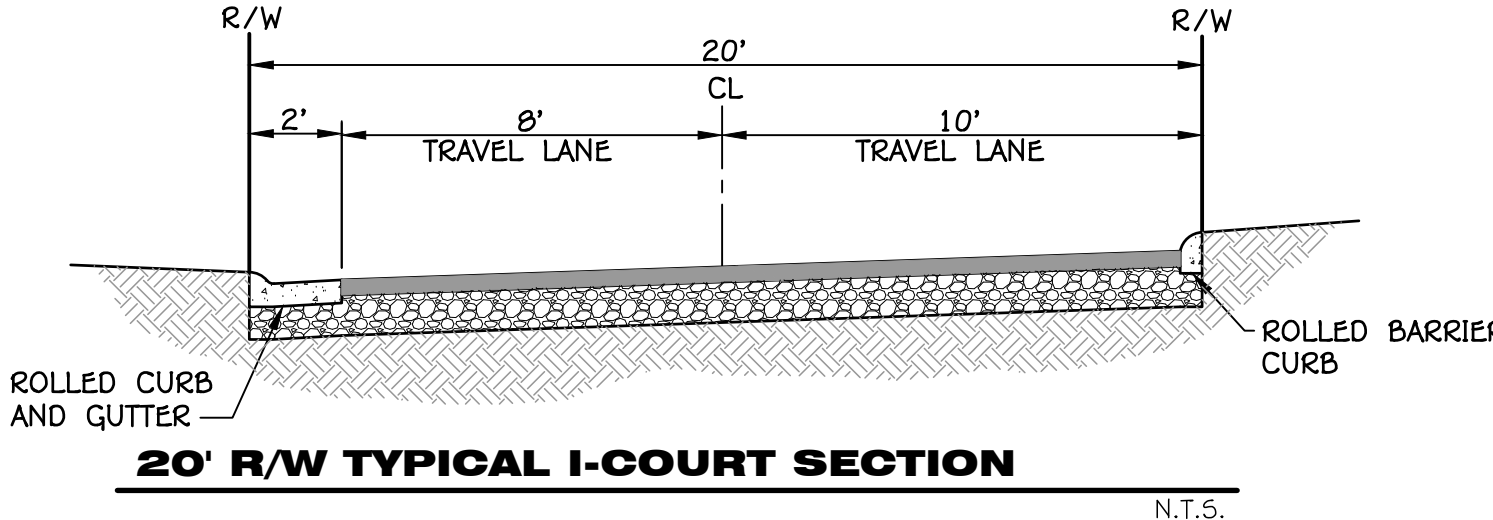

20' R/W TYPICAL I-COURT SECTION

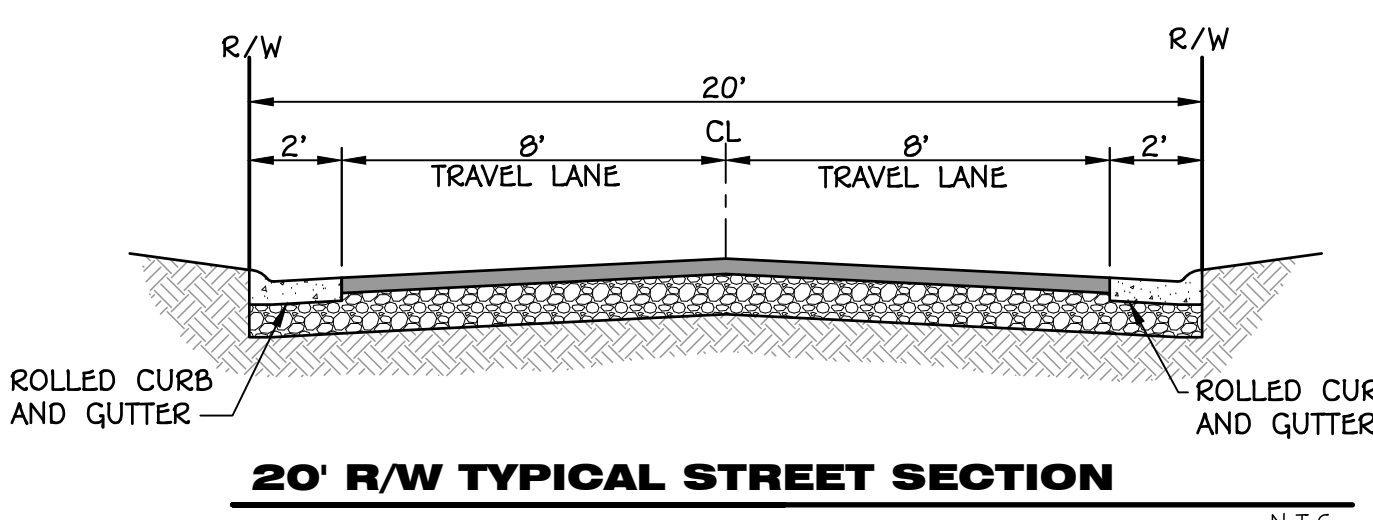

20' R/W TYPICAL STREET SECTION

TENTATIVE SUBDIVISION MAP



VESTING TENTATIVE MAP MODIFICATION

LEGEND

DESCRIPTIONS	(P) PROPOSED	(E) EXISTING
CENTERLINE	---	---
RIGHT OF WAY LINE	---	---
BOUNDARY LINE	---	---
ELECTRICAL LINE	---	---
GAS LINE	---	---
TELEPHONE LINE	---	---
SIDEWALK WITH CURB AND GUTTER	---	---

TENTATIVE SUBDIVISION MAP FOR:

FOUR 40 WEST

E STREET
CITY OF WEST SACRAMENTO, CALIFORNIA
JANUARY, 14 2021
SHEET 2 OF 3



1001 Enterprise Way, Suite 100 Roseville, CA 95678 (916) 783-8898

APPROVED FOR THE CITY OF WEST SACRAMENTO BY THE CITY ENGINEER ON 01/14/21. THIS MAP IS SUBJECT TO THE CITY ENGINEER'S REVIEW AND APPROVAL. THE CITY ENGINEER'S REVIEW IS LIMITED TO TECHNICAL ASPECTS AND DOES NOT CONSTITUTE A GUARANTEE OF THE ACCURACY OF THE INFORMATION PROVIDED. THE CITY ENGINEER'S REVIEW IS LIMITED TO TECHNICAL ASPECTS AND DOES NOT CONSTITUTE A GUARANTEE OF THE ACCURACY OF THE INFORMATION PROVIDED.

S:\Proj\233A Long Planning\W\233A-16.dwg 01/14/21 09:18:24am JArnes

TENTATIVE SUBDIVISION MAP MODIFICATION FOR:

FOUR 40 WEST

CITY OF WEST SACRAMENTO

CALIFORNIA

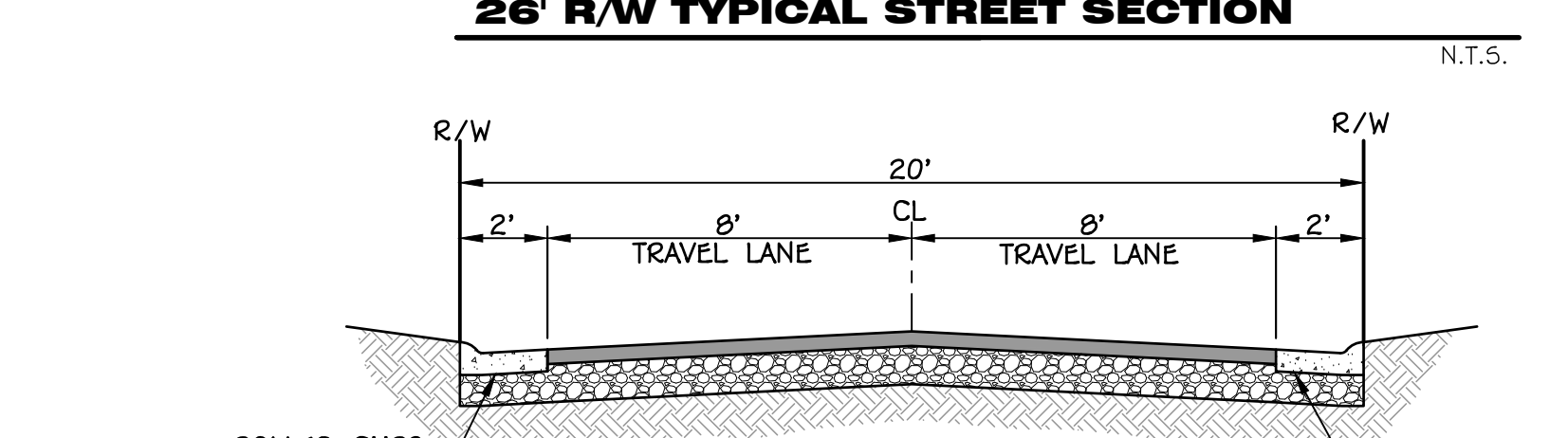
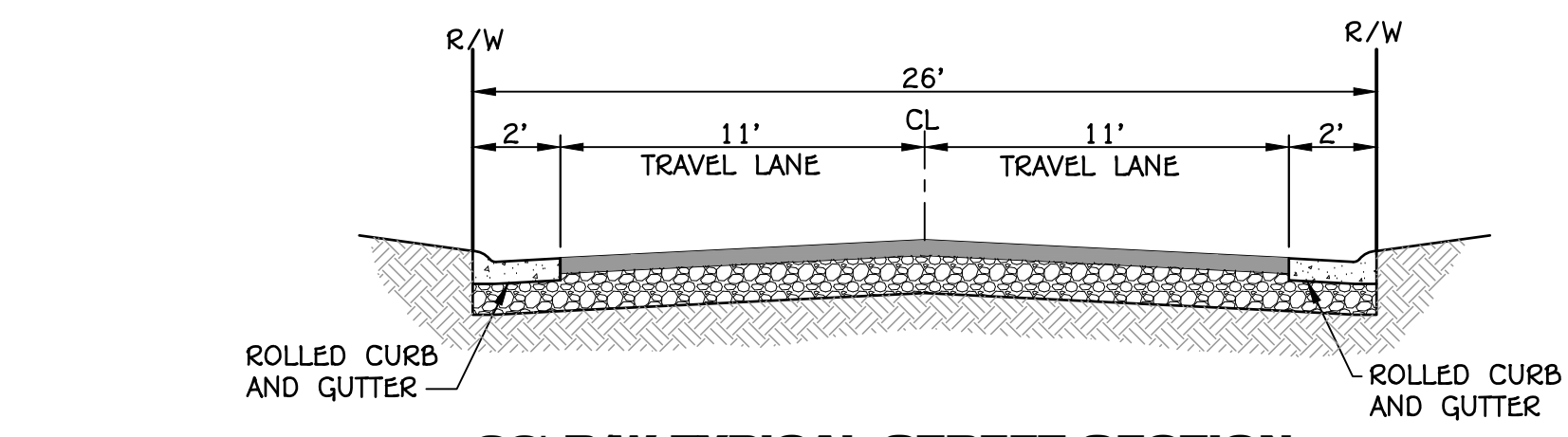
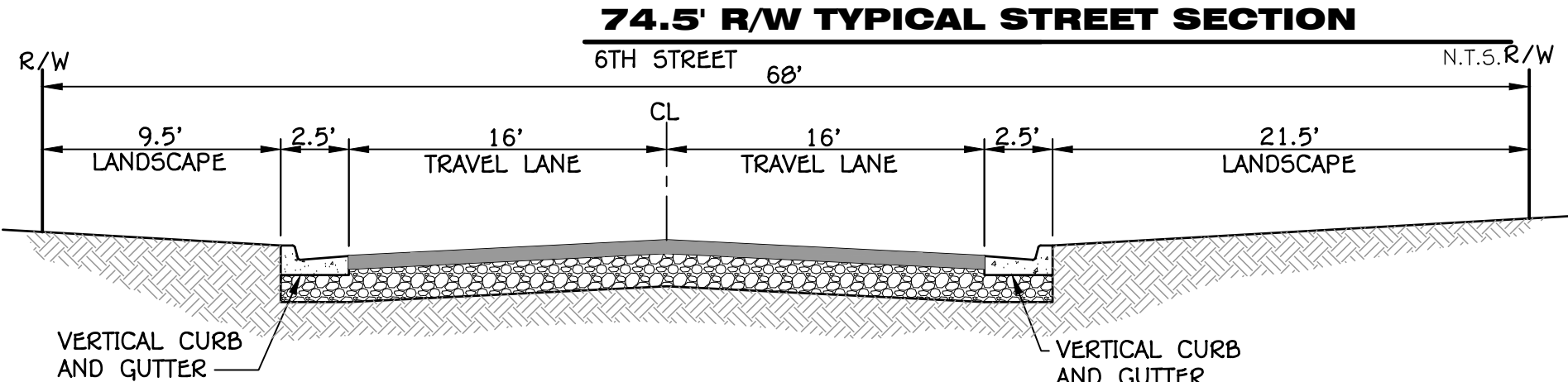
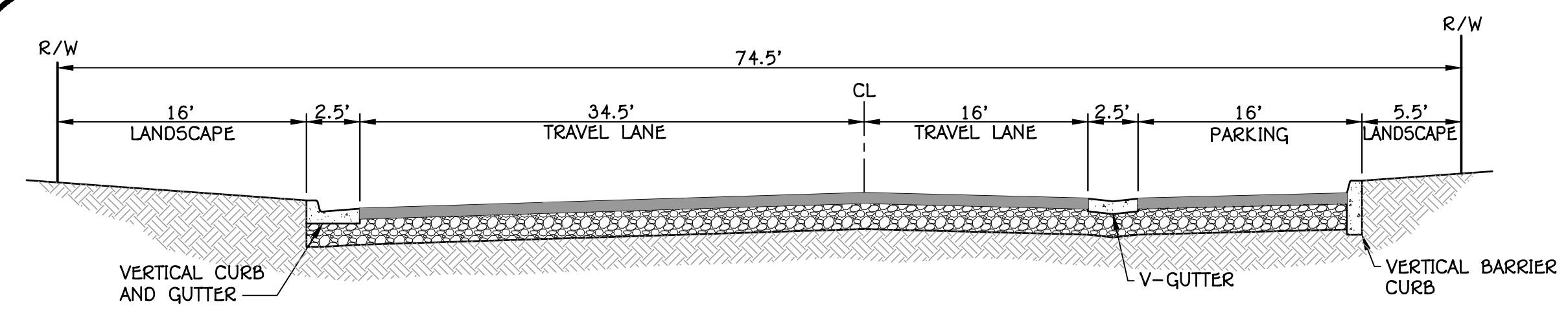
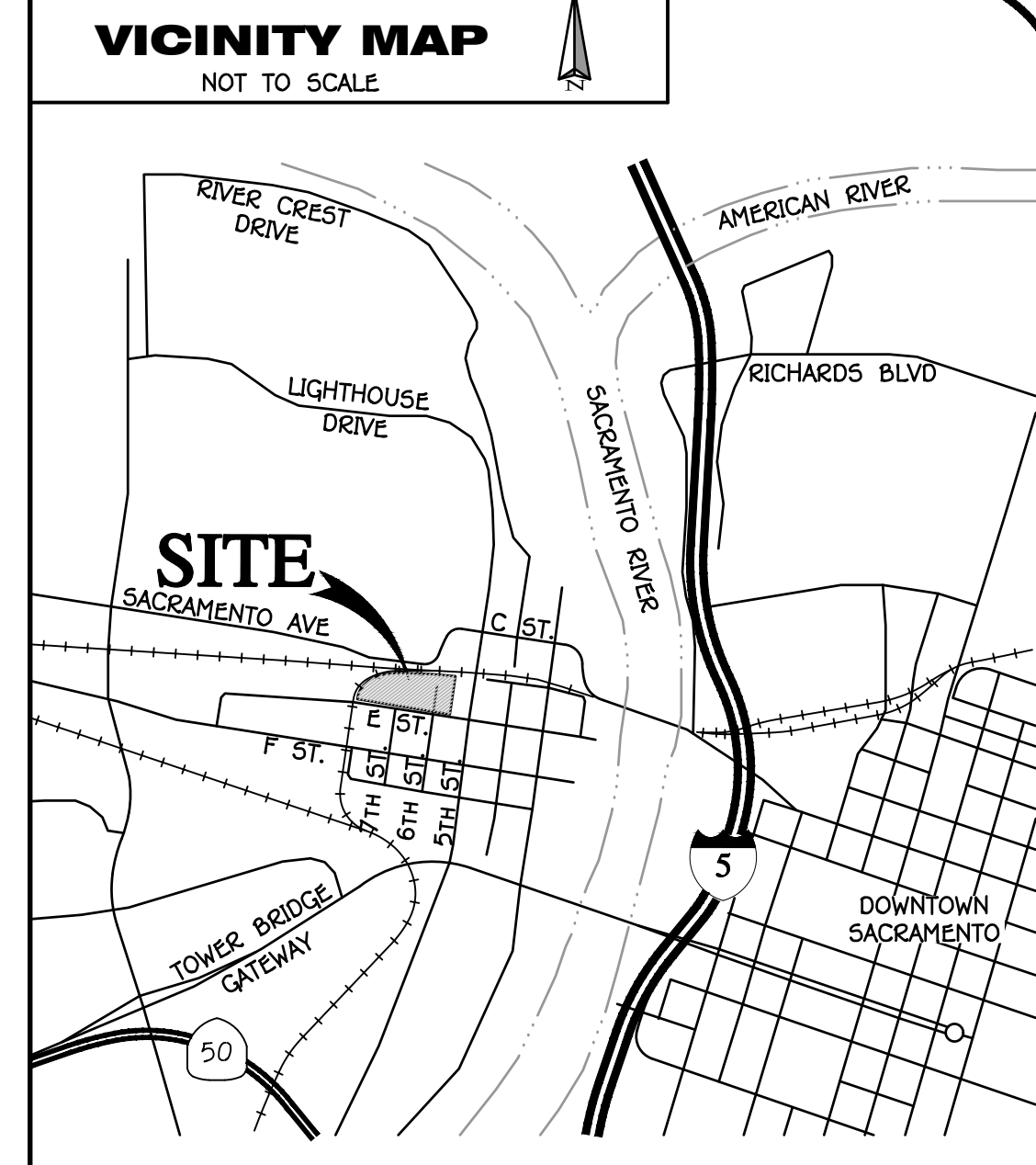
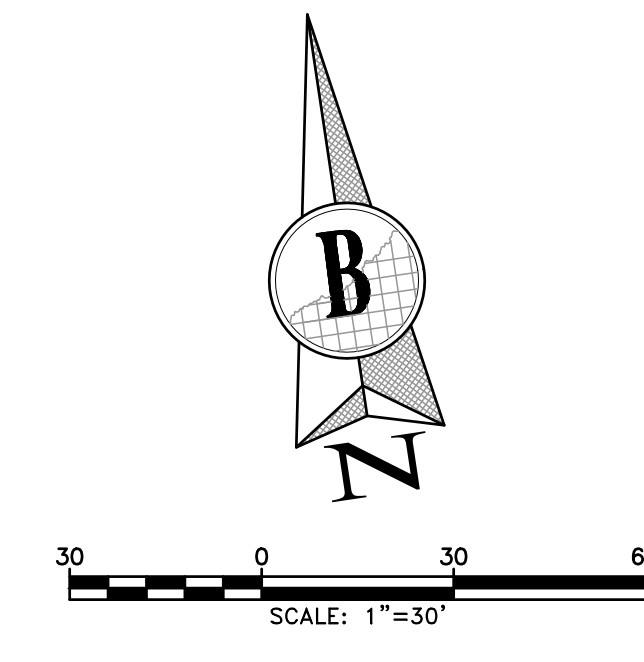

VESTING TENTATIVE MAP MODIFICATION



LEGEND

DESCRIPTIONS	(P) PROPOSED	(E) EXISTING
CENTERLINE	---	---
RIGHT OF WAY LINE	---	---
BOUNDARY LINE	---	---
ELECTRICAL LINE	---	---
GAS LINE	---	---
TELEPHONE LINE	---	---
SIDEWALK WITH CURB AND GUTTER	---	---

TENTATIVE SUBDIVISION MAP FOR:

FOUR 40 WEST

E STREET
CITY OF WEST SACRAMENTO, CALIFORNIA
JANUARY 14, 2021
SHEET 3 OF 3



1001 Enterprise Way, Suite 100 Roseville, CA 95678 (916) 783-8898

ALL INFORMATION CONTAINED HEREIN IS UNCLASSIFIED EXCEPT WHERE SHOWN OTHERWISE. DATE 01/14/2021 BY 60322/UC/BAW.

S:\Proj\233A\eng\Planning\1\W_233A-TM.dwg 01/14/21 09:18:35am JAW